

LE5238C

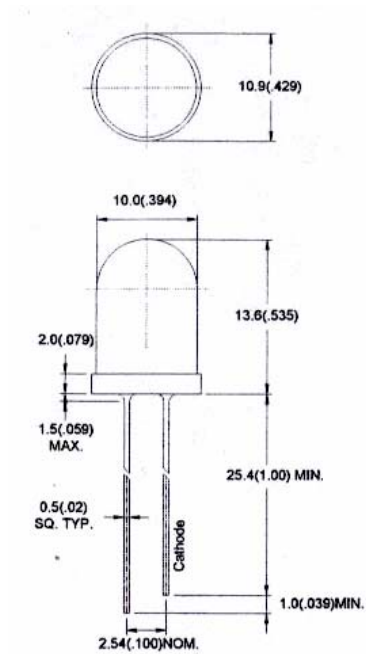

Note :

1. All dimension are in millimeters (inches).
2. Tolerance is $\pm 0.25\text{mm}$ (0.01") unless otherwise specified.
3. Lead spacing is measured where the leads emerge from the package.
4. Specifications are subject to change without notice.

Features:

1. Chip Material: GaAlAs
2. Emitted color : Red
3. Lens Appearance : Water Clear
4. Low Power consumption
5. High efficiency.
6. Versatile mounting on P.C. Board or panel.
7. Low current requirement.
8. 5mm diameter package.
9. This product don't contain restriction substance, compliance ROHS standard.

Application:

1. TV sets
2. Monitor
3. Telephone
4. Computer
5. Circuit board

| Parameter | Symbol | Rating | Unit |
|------------------------------------|-----------|-----------------------|------|
| Power Dissipation | P_d | 80 | mW |
| Forward Current | I_F | 30 | mA |
| Peak Forward Current ^{*1} | I_{FP} | 150 | mA |
| Reverse Voltage | V_R | 5 | V |
| Operating Temperature | T_{opr} | -40°C ~ 80°C | |
| Storage Temperature | T_{stg} | -40°C ~ 85°C | |
| Soldering Temperature | T_{sol} | 260°C (for 5 seconds) | |

*1 Condition for I_{FP} is pulse of 1/10 duty and 0.1msec width.

Megatone Electronics Corp.

Tel: +886-2-2951-0821 / Fax: +886-2-2593-1849

Email: orders@MegatoneCorp.com / mega.powe@msa.hinet.net

Electrical and optical characteristics (Ta=25°C)

| Parameter | Symbol | Condition | Min. | Typ. | Max. | Unit |
|--------------------------|-----------------|-------------------|-------------|-------------|-------------|---------------|
| Forward Voltage | V_F | $I_F=20\text{mA}$ | - | 1.8 | 2.3 | V |
| Luminous Intensity | I_V | $I_F=20\text{mA}$ | - | 3500 | - | Mcd |
| Reverse Current | I_R | $V_R=5\text{V}$ | - | - | 100 | μA |
| Peak Wave Length | λ_p | $I_F=20\text{mA}$ | - | 660 | - | nm |
| Dominant Wave Length | λ_d | $I_F=20\text{mA}$ | 652 | - | 668 | nm |
| Spectral Line Half-width | $\Delta\lambda$ | $I_F=20\text{mA}$ | - | 35 | - | nm |
| Viewing Angle | $2\theta_{1/2}$ | $I_F=20\text{mA}$ | - | 30 | - | deg |

Typical Electro-Optical Characteristics Curves

Fig.1 Relative intensity vs. Wavelength

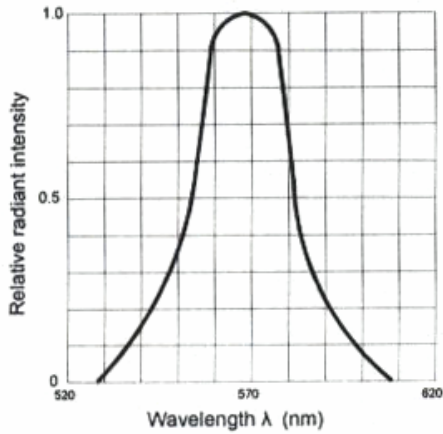

Fig.2 Forward current derating curve vs. Ambient temperature

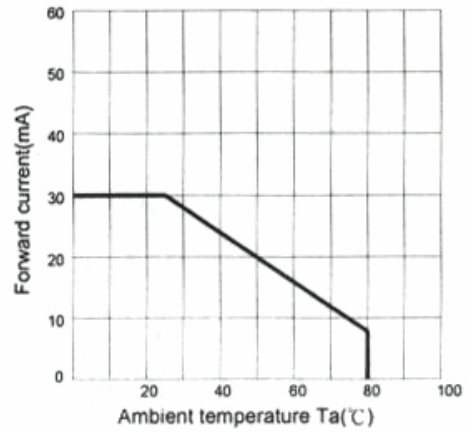

Fig.3 Forward current vs. Forward voltage

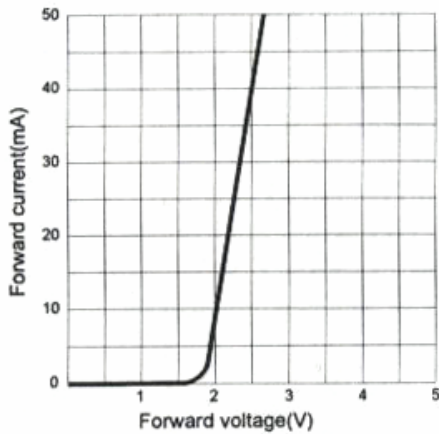

Fig.4 Relative luminous intensity vs. Ambient temperature

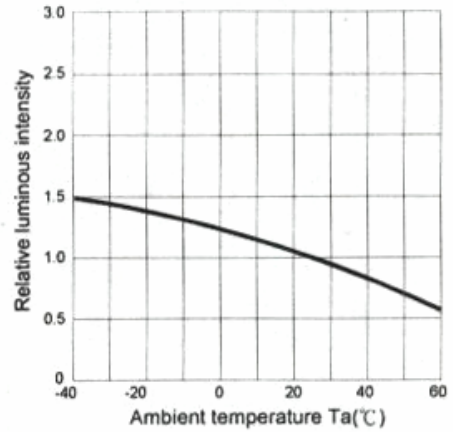

Fig.5 Relative luminous intensity vs. Forward current

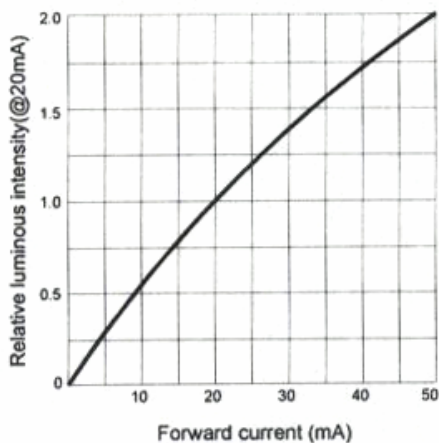

Fig.6 Radiation diagram

