

LE103SYC

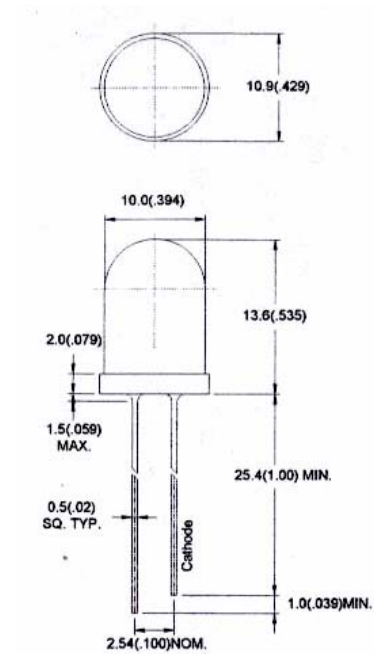

Note :

1. All dimension are in millimeters (inches).
2. Tolerance is $\pm 0.25\text{mm}$ (0.01") unless otherwise specified.
3. Lead spacing is measured where the leads emerge from the package.
4. Specifications are subject to change without notice.

Features:

1. Chip Material: AlGaInP/GaAs
2. Emitted color : Super Yellow
3. Lens Appearance : Water Clear
4. Low Power consumption
5. High efficiency.
6. Versatile mounting on P.C. Board or panel.
7. Low current requirement.
8. 10mm diameter package.
9. This product don't contain restriction substance, compliance ROHS standard.

Application:

1. TV sets
2. Monitor
3. Telephone
4. Computer
5. Circuit board

Parameter	Symbol	Rating	Unit
Power Dissipation	Pd	80	mW
Forward Current	I _F	30	mA
Peak Forward Current ^{*1}	I _{FP}	150	mA
Reverse Voltage	V _R	5	V
Operating Temperature	Topr	-40°C ~ 80°C	
Storage Temperature	Tstg	-40°C ~ 85°C	
Soldering Temperature	Tsol	260°C (for 5 seconds)	

^{*1} Condition for I_{FP} is pulse of 1/10 duty and 0.1msec width.

Megatone Electronics Corp.

Tel: +886-2-2951-0821 / Fax: +886-2-2593-1849

Email: orders@MegatoneCorp.com / mega.powe@msa.hinet.net

Electrical and optical characteristics (Ta=25°C)

Parameter	Symbol	Condition	Min.	Typ.	Max.	Unit
Forward Voltage	V_F	$I_F=20\text{mA}$	-	2.1	2.6	V
Luminous Intensity	I_V	$I_F=20\text{mA}$	-	1000	-	Mcd
Reverse Current	I_R	$V_R=5\text{V}$	-	-	100	μA
Peak Wave Length	λ_p	$I_F=20\text{mA}$	-	595	-	nm
Dominant Wave Length	λ_d	$I_F=20\text{mA}$	590	-	598	nm
Spectral Line Half-width	$\Delta\lambda$	$I_F=20\text{mA}$	-	15	-	nm
Viewing Angle	$2\theta_{1/2}$	$I_F=20\text{mA}$	-	25	-	deg

Typical Electro-Optical Characteristics Curves

Fig.1 Relative intensity vs. Wavelength

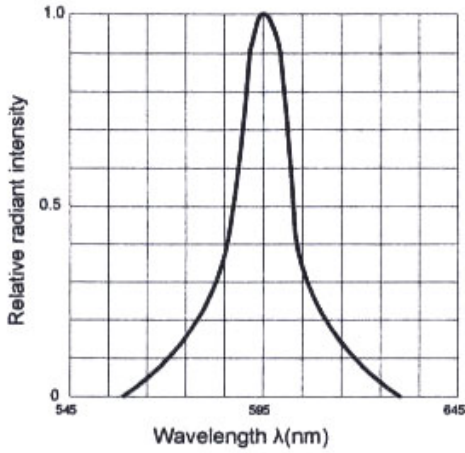

Fig.2 Forward current derating curve vs. Ambient temperature

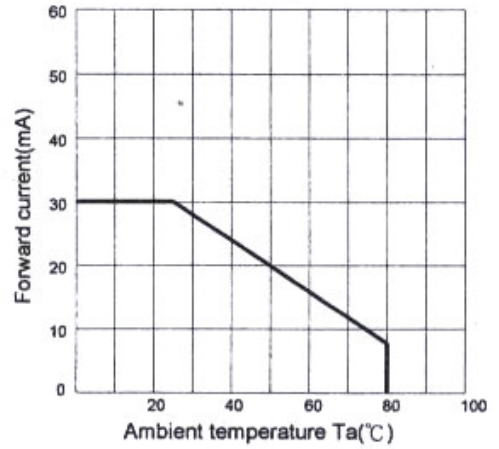

Fig.3 Forward current vs. Forward voltage

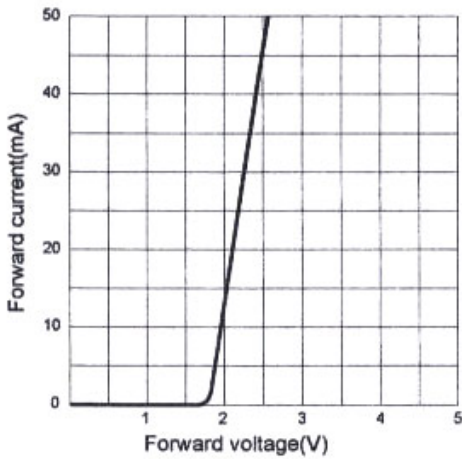

Fig.4 Relative luminous intensity vs. Ambient temperature

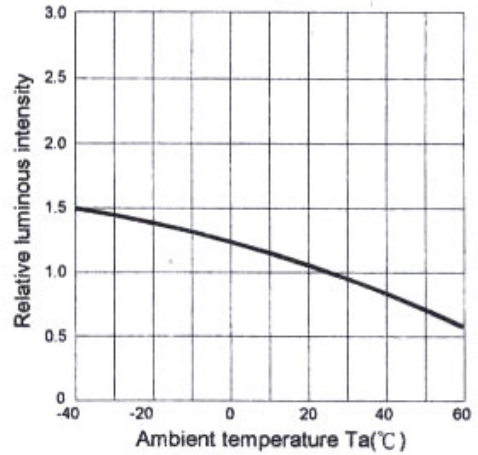

Fig.5 Relative luminous intensity vs. Forward current

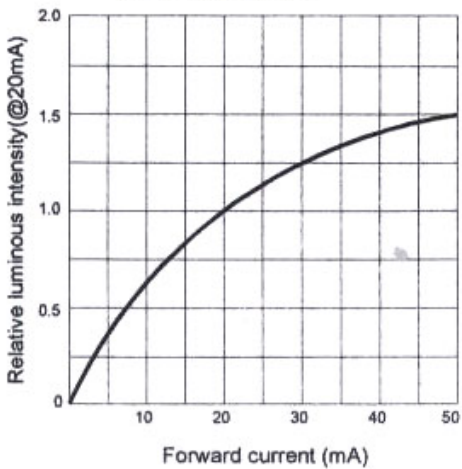

Fig.6 Radiation diagram

